

# Combined Nonlinear Feedback Strategy and Sliding Mode Controller for High Performance Matrix Converter-fed Induction Motor Drives

Abdelhakim Dendouga\*, Rachid Abdessemed\*,  
Najib Essounbouli\*\*

\* *LEB-Research Laboratory, Department of Electrical engineering, University of Batna, Batna, Algeria (Tel: +213-(0)790-03-64-12; (e-mail: hakimdendouga@yahoo.fr).*

\*\* *CRéSTIC Research Laboratory IUT, Troyes Troyes, France (e-mail: Najib.essounbouli@univ-reims.fr)*

**Abstract:** In this paper, a nonlinear feedback linearization approach and sliding mode controller are combined to generate the reference voltages for a matrix converter controlled by direct space vector modulation DSVM strategy fed induction motor in order to preserve the robustness with respect to desired dynamic behaviors for this drive system. The transfer function and the selection approach of the parameter for the input filter are also introduced. The simulation results of the robustness testing of the drive system have been carried out to validate the advantages of the proposed control system.

**Keywords:** Direct space vector modulation (DSVM), Induction motor (IM), LC Input filter, Matrix converter (MC), Nonlinear feedback control, Sliding mode controller (SMC).

## 1. INTRODUCTION

The three-phase MC consists of nine bidirectional switches, arranged as three sets of three so that any of the three input phases can be connected to any of the three output lines, as shown in Figure 1 (Dendouga et al., 2013; Huber and Borrojevic, 1995; Wheeler et al., 2002; Zhang et al., 1998; Casadei et al., 2002). During recent years, the MC technology has attracted the power electronics industry and the development progress has been accelerated. The main obstacles toward realizing an industrial MC have been overcome and initial steps toward developing a commercial product have already been taken (Watanabe et al., 2000). The MC has been found as interesting alternative to standard ac/dc/ac converters, this due to his many advantages such as: power converter adjustment capability and it does not involve a dc voltage link and the associated large capacitor as in the case of ac/dc/ac converter (capacitor between the rectifier and the inverter), and it allows bidirectional power flow. However, the MC presents disadvantages such as: the input grid voltage unbalances can result in unwanted output harmonic currents, which deteriorate the drive system performance, short-time voltage sag could interrupt the normal operation of load equipment, even causing some failures. In the literature two methods of control are adapted for the MC-Venturini and SVM methods; the main advantage of the SVM method lies in lower switching losses compared with the Venturini method. The Venturini method, however, exhibits superior performance in terms of harmonics (Zhang et al., 1998; Casadei et al., 2002).

In order to solve the filtering problem, the authors in (Rodriguez et al., 1995; Hongwu et al., 2009; Piriya Wong,

2007) propose various configurations of the input filter adopted for MC. In addition, the transfer function, the characteristics, and the selection approach parameters of any configurations are also presented (Hongwu et al., 2009). The conventional inductive capacitive (LC) filter is well adapted to filtering of harmonics, due to the simplicity of implementation, and satisfactory performance provided by this configuration.

Recently, significant research activity has been concentrated on the development of new control algorithms for matrix converter-fed induction motor drives systems. The field-oriented control allows a natural decoupling between the speed and flux amplitude. However, the parameter variations and the high operation speed cause decoupling loss, (Marino et al., 1993; Lee et al., 2006).

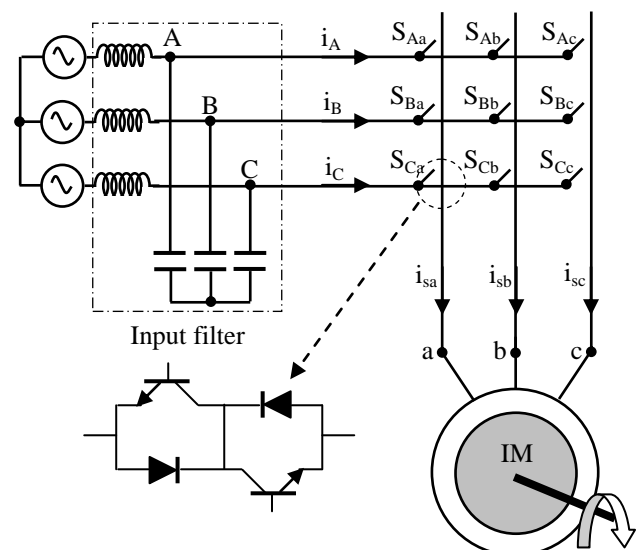

Fig. 1. Topology of MC fed IM drive system.

The nonlinear control is another alternative approach to achieve an asymptotic decoupling for induction motor while ensuring a perfect linearization some is the profiles of the reference trajectories imposed on the system. Several work (Bekhouché, 2009; Bakhti, 2007; Merabet, 2007), showed that this technique revealed interesting properties as for decoupling between electromagnetic torque and flux amplitude in term of the response time of the torque, and with the parametric variations robustness.

Recently, in (Sun et al., 2005) the nonlinear robust auto disturbance rejection controller (ADRC) is combined by the vector control to generate the reference voltage to the MC controlled by indirect SVM strategy in order to obtain a good performance of the induction motor drive system. The dynamic performance, the stability and reliability of the proposed control strategy under external disturbances have been verified by simulation results. This study constitutes an initiative for the application of nonlinear approach to control matrix converter fed induction motor drive system.

The essential objective of this paper is to realize a high performance control of MC fed IM drive system. The input-output feedback linearization technique and sliding mode controller are combined to generate the reference voltages for a matrix converter controlled by DSVM strategy fed induction motor in order to preserve the robustness with respect to desired dynamic behaviors for this drive system. The DSVM modulation strategy is employed to regulate the input/output sinusoidal waveforms of MC with unity input power factor operation condition, taking the place of conventional indirect SVM strategy. This approach has the advantage of an immediate comprehension of the switching strategies. In addition, the number of switch commutations within a cycle period can be limited utilizing an opportune commutation sequence (Casadei et al., 2002). Moreover, the transfer function and the parameter selection approach for the input filter are also introduced.

Finally, the robustness testing of the proposed drive system is verified by simulation. Knowing that the matrix converter is available like a prototype in certain research laboratories at the world level, for this reason we proposed a simulation study which made up a platform or the first stage towards a experimental study.

## 2. NONLINEAR FEEDBACK CONTROL

### 2.1 IM Model

Assuming linear magnetic circuits, the dynamics of a balanced non-saturated IM in a fixed reference frame ( $\alpha$ - $\beta$ ) attached to the stator, are given by (Marino et al., 1993; Bekhouché, 2009; Bakhti, 2007; Tarbouchi, 1997; Yazdanpanah et al., 2008):

$$\begin{cases} \dot{x} = f(x) + g(x)u \\ y = h(x) \end{cases} \quad (1)$$

where:

$$x = \begin{bmatrix} i_{s\alpha} & i_{s\beta} & \varphi_{r\alpha} & \varphi_{r\beta} & \omega \end{bmatrix}; u = \begin{bmatrix} v_{s\alpha} \\ v_{s\beta} \end{bmatrix};$$

$$f(x) = \begin{bmatrix} f_1(x) \\ f_2(x) \\ f_3(x) \\ f_4(x) \\ f_5(x) \end{bmatrix} = \begin{bmatrix} -\gamma i_{s\alpha} + \frac{K}{T_r} \varphi_{r\alpha} + Kn_p \omega \varphi_{r\beta} \\ -\gamma i_{s\beta} + \frac{K}{T_r} \varphi_{r\beta} - Kn_p \omega \varphi_{r\alpha} \\ \frac{L_m}{T_r} i_{s\alpha} - \frac{1}{T_r} \varphi_{r\alpha} - n_p \omega \varphi_{r\beta} \\ \frac{L_m}{T_r} i_{s\beta} - \frac{1}{T_r} \varphi_{r\beta} + n_p \omega \varphi_{r\alpha} \\ \frac{n_p L_m}{J L_r} (\varphi_{r\alpha} i_{s\beta} - \varphi_{r\beta} i_{s\alpha}) - \frac{1}{J} (B\omega + T_r) \end{bmatrix};$$

$$g = \begin{bmatrix} g_1 & g_2 \end{bmatrix} = \begin{bmatrix} \frac{1}{\sigma L_s} & 0 \\ 0 & \frac{1}{\sigma L_s} \\ 0 & 0 \\ 0 & 0 \\ 0 & 0 \end{bmatrix}.$$

In which:  $i_{s\alpha}$ ,  $i_{s\beta}$ ,  $v_{s\alpha}$ ,  $v_{s\beta}$ ,  $\varphi_{r\alpha}$ ,  $\varphi_{r\beta}$ , are the components of the space vectors of the stator currents and voltages, rotor flux;  $R_r$ ,  $R_s$ ,  $L_s$ ,  $L_r$  are resistances and inductances of the stator and rotor windings;  $L_m$  is magnetizing inductance;  $\omega$  the rotor speed;  $T_r$  the external torque applied to the IM;  $T_e$  the torque produced by the IM;  $n_p$  the number of pole pairs;  $J$  the total rotor inertia and  $B$  the viscous friction coefficient.

The positive constants, related to electrical mechanical parameters of the IM are defined as:

$$T_r = \frac{L_r}{R_r}, \sigma = 1 - \frac{L_m}{L_s L_r}, \gamma = \frac{1}{\sigma L_s} \left( R_s + \frac{L_m^2}{L_r T_r} \right), K = \frac{L_m}{\sigma L_s L_r}$$

In order to achieve fast torque response as well as operate in the flux weakened region and maximize the power efficiency for the IM drive, the torque ( $T_e$ ) and the norm of the rotor flux linkage ( $\varphi_{r\alpha}^2 + \varphi_{r\beta}^2$ ) are assumed to be the system outputs.

$$h(x) = \begin{bmatrix} h_1(x) \\ h_2(x) \end{bmatrix} = \begin{bmatrix} T_e \\ \varphi_r^2 \end{bmatrix} = \begin{bmatrix} \frac{n_p L_m}{L_r} (\varphi_{r\alpha} i_{s\beta} - \varphi_{r\beta} i_{s\alpha}) \\ \varphi_{r\alpha}^2 + \varphi_{r\beta}^2 \end{bmatrix} \quad (2)$$

### 2.2 Nonlinear feedback control

The following notation is used for the ‘‘Lie’’ derivative of a function  $h(x): \mathfrak{R}^n \rightarrow \mathfrak{R}$  along a vector  $f(x) = (f_1(x), \dots, f_n(x))$ , (Merabet, 2007; Slotine, 1991)

$$L_f h(x) = \sum_{i=1}^n \frac{\partial h(x)}{\partial x_i} f_i(x) \quad (3)$$

$$L_f^i = L_f(L_f^{i-1} h(x))$$

Using the IM fifth order model (1), the derivatives of the outputs are given by:

▪ For the first output:  $y_1 = h_1(x) = T_e$

$$\dot{y}_1 = \dot{h}_1(x) = L_f h_1(x) + L_{g_1} h_1(x) v_{s\alpha} + L_{g_2} h_1(x) v_{s\beta} \quad (4)$$

Using the above notation, one can obtain that

$$\begin{cases} L_f h_1(x) = \frac{n_p L_m}{L_r} \left[ \left( \gamma + \frac{1}{T_r} \right) (\varphi_{r\beta} i_{s\alpha} - \varphi_{r\alpha} i_{s\beta}) - K n_p \omega (\varphi_{r\alpha}^2 + \varphi_{r\beta}^2) - n_p \omega (\varphi_{r\alpha} i_{s\alpha} + \varphi_{r\beta} i_{s\beta}) \right] \\ L_{g_1} h_1(x) = \frac{\partial h_1(x)}{\partial x_i} g_1 = -\frac{n_p L_m}{\sigma L_r L_s} \varphi_{r\beta} \\ L_{g_2} h_1(x) = \frac{\partial h_1(x)}{\partial x_i} g_2 = \frac{n_p L_m}{\sigma L_r L_s} \varphi_{r\alpha} \end{cases} \quad (5)$$

The relative degree corresponds the first output is:  $r_1=1$ .

▪ For the second output:  $y_2 = h_2(x) = \varphi_r^2$

$$\begin{cases} \dot{y}_2 = \dot{h}_2(x) = L_f h_2(x) \\ \ddot{y}_2 = \ddot{h}_2(x) = L_f^2 h_2(x) + L_{g_1} (L_f h_2(x)) v_{s\alpha} + L_{g_2} (L_f h_2(x)) v_{s\beta} \end{cases} \quad (6)$$

where

$$\begin{cases} L_f h_2(x) = \frac{2L_m}{T_r} (\varphi_{r\alpha} i_{s\alpha} + \varphi_{r\beta} i_{s\beta}) - \frac{2}{T_r} (\varphi_{r\alpha}^2 + \varphi_{r\beta}^2) \\ L_f^2 h_2(x) = \frac{-2L_m}{T_r} \left[ \left( \gamma + \frac{3}{T_r} \right) (\varphi_{r\alpha} i_{s\alpha} + \varphi_{r\beta} i_{s\beta}) + n_p \omega (\varphi_{r\beta} i_{s\alpha} - \varphi_{r\alpha} i_{s\beta}) \right] + \left( \frac{2KL_m + 4}{T_r^2} (\varphi_{r\alpha}^2 + \varphi_{r\beta}^2) + \frac{2L_m^2}{T_r^2} (i_{r\alpha}^2 + i_{r\beta}^2) \right) \\ L_{g_1} (L_f h_2(x)) = \frac{\partial (L_f h_2(x))}{\partial x_i} g_1 = \frac{2L_m}{\sigma L_s T_r} \varphi_{r\alpha} \\ L_{g_2} (L_f h_2(x)) = \frac{\partial (L_f h_2(x))}{\partial x_i} g_2 = \frac{2L_m}{\sigma L_s T_r} \varphi_{r\beta} \end{cases} \quad (7)$$

The relative degree corresponds the second output is:  $r_2=1$ . Consequently, the total relative degree  $r=r_1+r_2=3$ . In this case, the full linearization is not realized.

For this reason, the following change of coordinates is indispensable (Marino et al., 1993):

$$\begin{cases} z_1 = y_1 \\ z_2 = y_2 \\ z_3 = \dot{z}_2 = L_f h_2(x) \\ z_4 = \arctan \left( \frac{\varphi_{r\beta}}{\varphi_{r\alpha}} \right) \\ z_5 = \omega \end{cases} \quad (8)$$

Thus the derivatives of the outputs are given by:

$$\begin{cases} \dot{z}_1 = v_1 \\ \dot{z}_2 = z_3 \\ \dot{z}_3 = v_2 \\ \dot{z}_4 = n_p \omega + \frac{R_r z_1}{n_p z_2} \\ \dot{z}_5 = \frac{1}{J} (z_1 - T_r - f z_5) \end{cases} \quad (9)$$

From (9), (8), (6) and (4), the new inputs  $v_1$  and  $v_2$  of system are designed as

$$\begin{bmatrix} v_1 \\ v_2 \end{bmatrix} = \begin{bmatrix} L_f h_1 \\ L_f^2 h_2 \end{bmatrix} + D(x) \begin{bmatrix} v_{s\alpha} \\ v_{s\beta} \end{bmatrix} \quad (10)$$

Where  $D(x)$  is the decoupled matrix defined as

$$D(x) = \begin{bmatrix} L_{g_1} h_1 & L_{g_2} h_1 \\ L_{g_1} L_f h_2 & L_{g_2} L_f h_2 \end{bmatrix} = \begin{bmatrix} -\frac{n_p L_m}{\sigma L_r L_s} \varphi_{r\beta} & \frac{n_p L_m}{\sigma L_r L_s} \varphi_{r\alpha} \\ \frac{2L_m}{\sigma L_s T_r} \varphi_{r\alpha} & \frac{2L_m}{\sigma L_s T_r} \varphi_{r\beta} \end{bmatrix} \quad (11)$$

Since  $\det(D(x)) \neq 0$ ,  $D(x)$  is nonsingular everywhere in  $\omega$ .

The input-output linearizing feedback for system (10) is given by

$$\begin{bmatrix} v_{s\alpha} \\ v_{s\beta} \end{bmatrix} = D^{-1}(x) \begin{bmatrix} v_1 - L_f h_1 \\ v_2 - L_f^2 h_2 \end{bmatrix} \quad (12)$$

### 2.3 Sliding mode controller

In order to track desired smooth reference signals  $\omega_{ref}$ ,  $T_{ref}$  and  $\varphi_{rref}^2$  for the speed  $z_5 = \omega$ , the torque  $z_1 = T_e$  and the square of the rotor flux  $z_2 = \varphi_r^2$ , three sliding mode controllers are designed (Yazdanpanah and al., 2008).

▪ For the speed

The slip surface is selected as

$$S(z_5) = e(z_5) = z_{5ref} - z_5 \quad (13)$$

its time derivate is expressed by

$$\dot{S}(z_5) = \dot{z}_{5ref} - \dot{z}_5 \quad (14)$$

Under sliding mode condition ( $\dot{S}(z_5)=0$ ), and from the model (1), the equivalent component of the reference torque is given by

$$(z_{1ref})_{eq} = \dot{z}_{5ref} + \frac{1}{J}(fz_{5ref} + T_r) \tag{15}$$

In order to reduce the chattering phenomenon due to the discontinuous nature of the SM controller, a smooth function is used for the nonlinear component

$$(z_{1ref})_n = k_\omega \frac{S(z_5)}{|S(z_5)| + \epsilon_\omega} \tag{16}$$

$k_\omega, \epsilon_\omega$ : are positive constants.

The SM controller for the speed is defined by

$$z_{1ref} = (z_{1ref})_{eq} + (z_{1ref})_n \tag{17}$$

▪ *For the Torque and the flux*

By using the same preceding stages, in this case, the slip surfaces for the torque and the speed are selected as

$$\begin{cases} S(z_1) = e(z_1) = z_{1ref} - z_1 \\ S(z_2) = \dot{e}(z_2) + \lambda e(z_2) = (\dot{z}_{2ref} - \dot{z}_2) + \lambda(z_{2ref} - z_2) \end{cases} \tag{18}$$

The SM controller is designed by

$$\begin{cases} v_1 = v_{1eq} + v_{1n} \\ v_2 = v_{2eq} + v_{2n} \end{cases} \tag{19}$$

where, the equivalent components are defined by

$$\begin{cases} v_{1eq} = z_{1ref} \\ v_{2eq} = \ddot{z}_{2ref} + \lambda(\dot{z}_{2ref} - \dot{z}_2) \end{cases} \tag{20}$$

The nonlinear components are given by

$$\begin{cases} v_{1n} = k_{T_e} \frac{S(z_1)}{|S(z_1)| + \epsilon_{T_e}} \\ v_{2n} = k_{\phi_r} \frac{S(z_2)}{|S(z_2)| + \epsilon_{\phi_r}} \end{cases} \tag{21}$$

$k_{T_e}, k_{\phi_r}, \epsilon_{T_e}, \epsilon_{\phi_r}, \lambda$ : are positive constants.

### 3. DIRECT SPACE VECTOR MODULATION

The direct space vector modulation (DSVM) represents the three-phase input currents and output line-to-line voltages as space vectors by  $\vec{i}_i$  and  $\vec{v}_o$  (figure 2). It is based on the concept of approximating a rotating reference voltage vector with those voltages physically realisable on a matrix converter.

For nine bidirectional switches, there are 27 possible

switching configurations available in which only 21 are commonly utilized to generate the desired space vectors in the DSVM control method (Table 1). These 21 configurations (Table 1) in which may be divided into four groups (Watanabe et al., 2000; Casadei et al., 2002; Hongwu et al., 2009)

The first three groups ( $\pm 1, \pm 2, \pm 3, \pm 4, \pm 5, \pm 6, \pm 7, \pm 8, \pm 9$ ) have two common features; namely, each of them consists of six vectors holding constant angular positions and each of them formulates a six-sextant hexagon as shown in Fig. 2. The general formulae to calculate the on-time durations, have been given as

$$\delta_1 = \frac{2}{\sqrt{3}} q \sin \left[ \alpha_o - (k_v - 1) \frac{\pi}{3} \right] \sin \left[ \frac{\pi}{6} - \left( \alpha_i - (k_i - 1) \frac{\pi}{3} \right) \right] \tag{22}$$

$$\delta_2 = \frac{2}{\sqrt{3}} q \sin \left[ \alpha_o - (k_v - 1) \frac{\pi}{3} \right] \sin \left[ \frac{\pi}{6} + \left( \alpha_i - (k_i - 1) \frac{\pi}{3} \right) \right] \tag{23}$$

$$\delta_3 = \frac{2}{\sqrt{3}} q \sin \left[ k_v \frac{\pi}{3} - \alpha_o \right] \sin \left[ \frac{\pi}{6} - \left( \alpha_i - (k_i - 1) \frac{\pi}{3} \right) \right] \tag{24}$$

$$\delta_4 = \frac{2}{\sqrt{3}} q \sin \left[ k_v \frac{\pi}{3} - \alpha_o \right] \sin \left[ \frac{\pi}{6} + \left( \alpha_i - (k_i - 1) \frac{\pi}{3} \right) \right] \tag{25}$$

$$\delta_0 = 1 - (\delta_1 + \delta_2 + \delta_3 + \delta_4) \tag{26}$$

where  $q = V_o/V_i$  is the voltage transfer ratio,  $\alpha_o$  and  $\alpha_i$  are the phase angles of the output voltage and input current vectors, respectively, and  $k_v, k_i$  are the output voltage sector and input current vector sector.

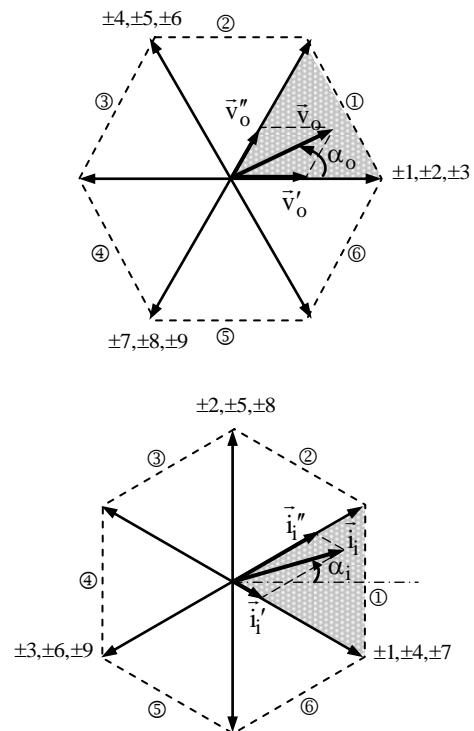

Fig. 2. Output voltage and input current space vectors.

**Table 1. Switching configuration used in DSVM.**

Swit Conf.	Switches on	$V_o$	$\alpha_o$	$I_i$	$\alpha_i$
+1	$S_{aA} S_{bB} S_{cC}$	$2/3V_{ab}$	0	$2/\sqrt{3} i_A$	$-\pi/6$
-1	$S_{bA} S_{aB} S_{aC}$	$2/3V_{ab}$	0	$-2/\sqrt{3} i_A$	$-\pi/6$
+2	$S_{bA} S_{cB} S_{cC}$	$2/3V_{bc}$	0	$2/\sqrt{3} i_A$	$\pi/2$
-2	$S_{cA} S_{bB} S_{bC}$	$-2/3V_{bc}$	0	$-2/\sqrt{3} i_A$	$\pi/2$
+3	$S_{cA} S_{aB} S_{aC}$	$2/3V_{ca}$	0	$2/\sqrt{3} i_A$	$7\pi/6$
-3	$S_{aA} S_{cB} S_{cC}$	$-2/3V_{ca}$	0	$-2/\sqrt{3} i_A$	$7\pi/6$
+4	$S_{bA} S_{aB} S_{bC}$	$2/3V_{ab}$	$2\pi/3$	$2/\sqrt{3} i_B$	$-\pi/6$
-4	$S_{aA} S_{bB} S_{aC}$	$-2/3V_{ab}$	$\pi/3$	$-2/\sqrt{3} i_B$	$-\pi/6$
+5	$S_{cA} S_{bB} S_{cC}$	$2/3V_{bc}$	$\pi/3$	$2/\sqrt{3} i_B$	$\pi/2$
-5	$S_{bA} S_{cB} S_{bC}$	$-2/3V_{bc}$	$2\pi/3$	$-2/\sqrt{3} i_B$	$\pi/2$
+6	$S_{aA} S_{cB} S_{aC}$	$2/3V_{ca}$	$2\pi/3$	$2/\sqrt{3} i_B$	$7\pi/6$
-6	$S_{cA} S_{aB} S_{cC}$	$-2/3V_{ca}$	$2\pi/3$	$-2/\sqrt{3} i_B$	$7\pi/6$
+7	$S_{bA} S_{bB} S_{aC}$	$2/3V_{ab}$	$4\pi/3$	$2/\sqrt{3} i_C$	$-\pi/6$
-7	$S_{aA} S_{aB} S_{bC}$	$-2/3V_{ab}$	$4\pi/3$	$-2/\sqrt{3} i_C$	$-\pi/6$
+8	$S_{cA} S_{cB} S_{bC}$	$2/3V_{bc}$	$4\pi/3$	$2/\sqrt{3} i_C$	$\pi/2$
-8	$S_{bA} S_{bB} S_{cC}$	$-2/3V_{bc}$	$4\pi/3$	$-2/\sqrt{3} i_C$	$\pi/2$
+9	$S_{aA} S_{aB} S_{cC}$	$2/3V_{ca}$	$4\pi/3$	$-2/\sqrt{3} i_C$	$7\pi/6$
-9	$S_{cA} S_{cB} S_{aC}$	$-2/3V_{ca}$	$4\pi/3$	$2/\sqrt{3} i_C$	$7\pi/6$
$0_a$	$S_{aA} S_{aB} S_{aC}$	0	-	0	-
$0_b$	$S_{bA} S_{bB} S_{bC}$	0	-	0	-
$0_c$	$S_{cA} S_{cB} S_{cC}$	0	-	0	-

#### 4. INPUT FILTER ANALYSIS AND MODELLING

The input filter can be modelled with the aid of the single-phase equivalent circuit (Fig. 3), by the following equations (Dendouga et al., 2013; Hongwu et al., 2009; Piriya Wong, 2007):

$$\begin{cases} V_A(s) = \frac{V_{fA}(s) - (L_f s + R_f) I_A(s)}{L_f C_f s^2 + R_f C_f s + 1} \\ I_{fA}(s) = \frac{1}{L_f C_f s^2 + R_f C_f s + 1} [I_A(s) + s C_f V_{fA}(s)] \end{cases} \quad (27)$$

where  $x(s)$  denotes the Laplace transfer function of  $x(t)$ .

From (27), the characteristic frequency  $\omega_n$  and damping factor  $\zeta$  of the transfer functions are :

$$\begin{cases} \omega_n = 1 / \sqrt{L_f C_f} \\ \zeta = \frac{1}{2} R_f \sqrt{C_f / L_f} \end{cases} \quad (28)$$

The design of the input filter has to accomplish the following:

- the value of  $C_f/L_f$  is usually less than 1;
- the damping factor  $\zeta$  is usually very small and approaches zero;
- the cut-off frequency of the input filter is lower the switching frequency (If near 10 KHz switching frequencies are considered, the filter should have a cut-off frequency of kHz to 2kHz).

#### 5. SYNOPTIC DIAGRAM, RESULTS AND DISCUSSIONS

In order to verify the robustness of the proposed control scheme of the induction motor fed by matrix converter (fig.4), the numerical simulations have been carried out, with the parameters of drive system are reported in Appendix.

The simulation test involves the following operating sequences (fig. 5): at the beginning, the motor operate in unloaded mode, with speed reference 100 rd/s and square rotor flux reference 1Wb. At  $t=0.5s$ , a 20 Nm load torque is applied, then, this torque is reversed (-20 Nm) with  $t=1s$  (fig.5.b), it is interesting to take into account that the torque inversion test is suitable only for one bidirectional converter like the MC, since in this case the motor is a function in generating mode. At  $t=1.5s$ , the motor is unloaded again. At  $t=2$ , the square of rotor flux reference takes 0.5 Wb as value, and then it returns to its initial value 1 Wb for  $t=2.5s$  (fig.5.c). At  $t=3s$ , the reference speed is reversed from 100 rd/s to -100 rd/s (fig.5.a). Where, the reference signals for torque and square rotor flux, consist of step functions.

According to figure 5, one can see that the dynamic performances of nonlinear control law are satisfactory: no steady-state errors occur; the decoupling between torque and square of rotor flux, is established (fig.5.b,c), excepting for a small flux error occurs; the responses of speed and square of rotor flux quickly converge to their reference values. In addition, a sinusoidal waveform is obtained for the phase stator current (fig.5.d).

From figure 6, one can note that the output MC voltage (stator phase voltage) which is reconstructed by the chopped three-phase input voltage (fig.6.a); the input MC voltage is highly sinusoidal (fig.6.b). The almost sinusoidal nature of the output MC current (stator phase current) and the current of input filter has also been observed.

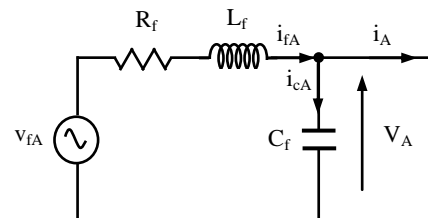

Fig. 3. Single phase equivalent circuit of input filter.

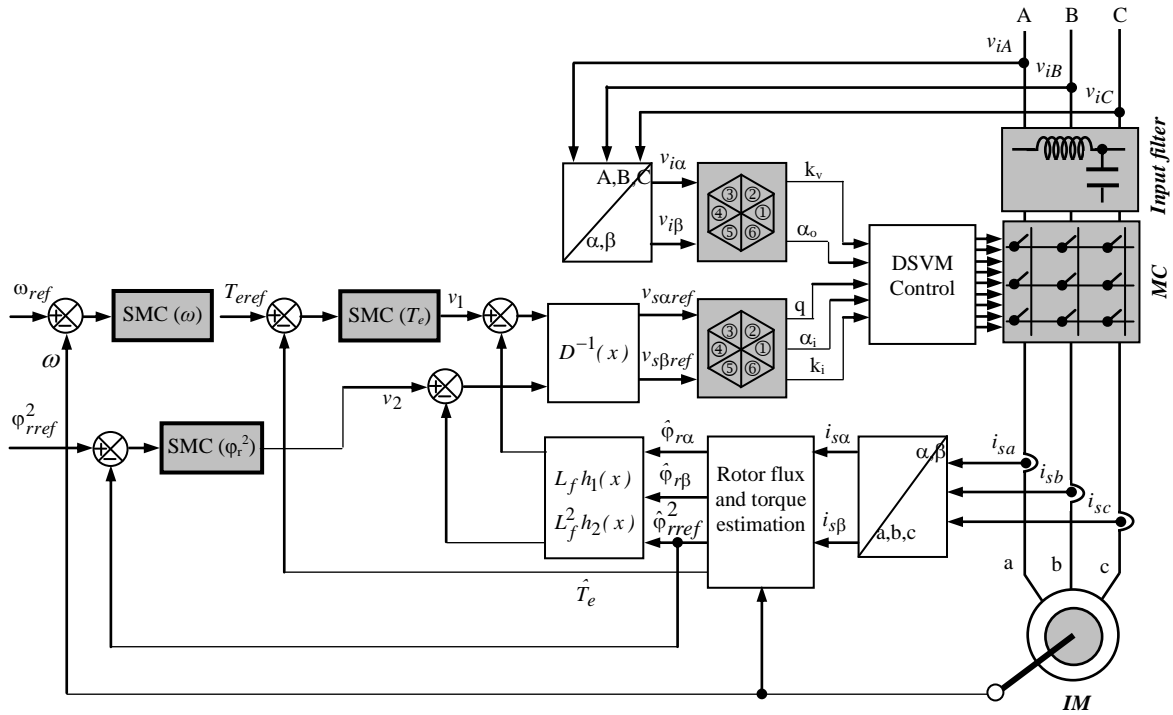

Fig. 4. Diagram block of the combined nonlinear feedback control and DSVM for MC fed IM.

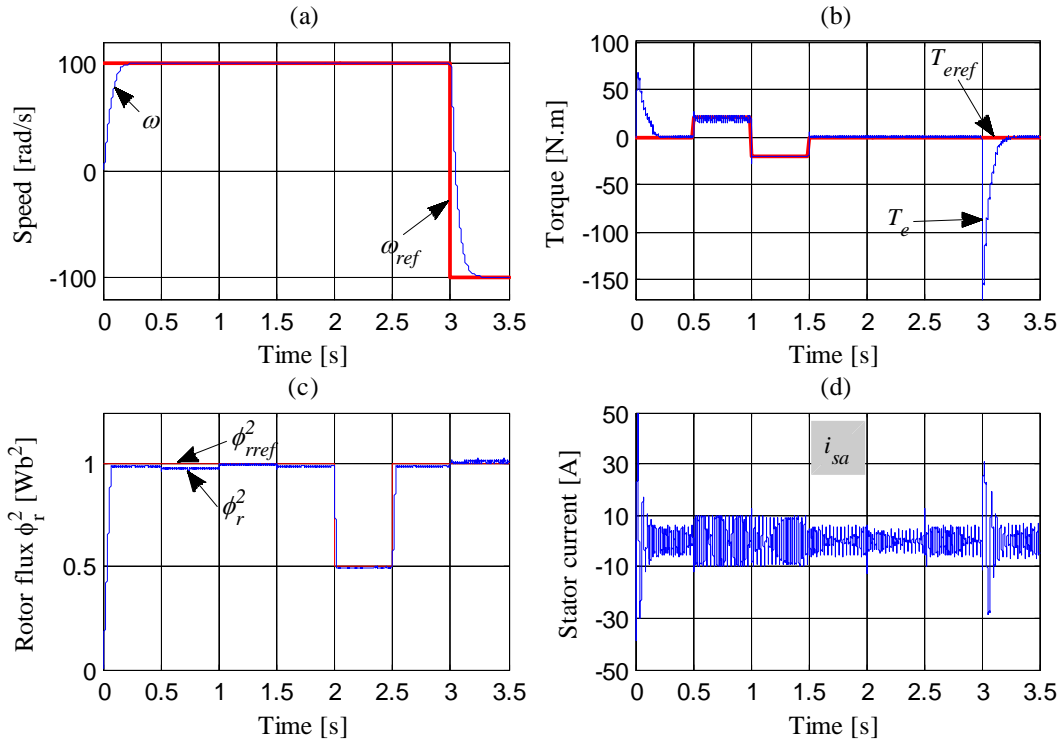

Fig. 5. Results of : (a) Speed; (b) torque; (c) square of the rotor flux; (d) stator current (output MC current).

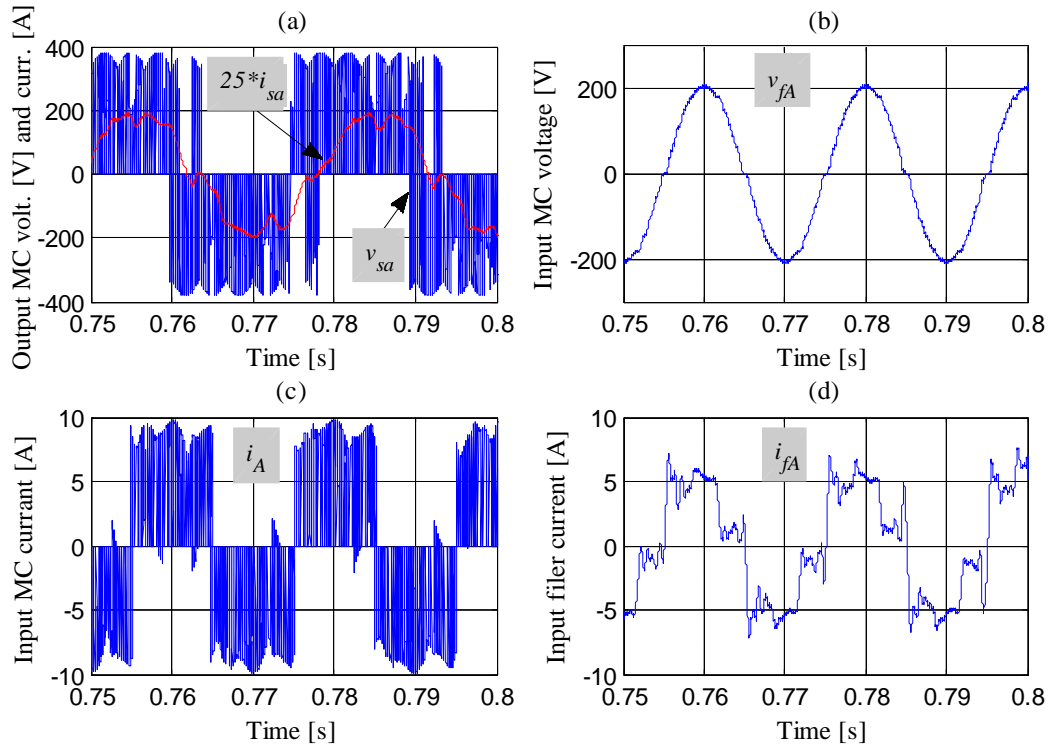

Fig. 6. Results of: (a) output MC voltage and current; (b) input MC voltage; (c) input MC current; (d) input current of the filter.

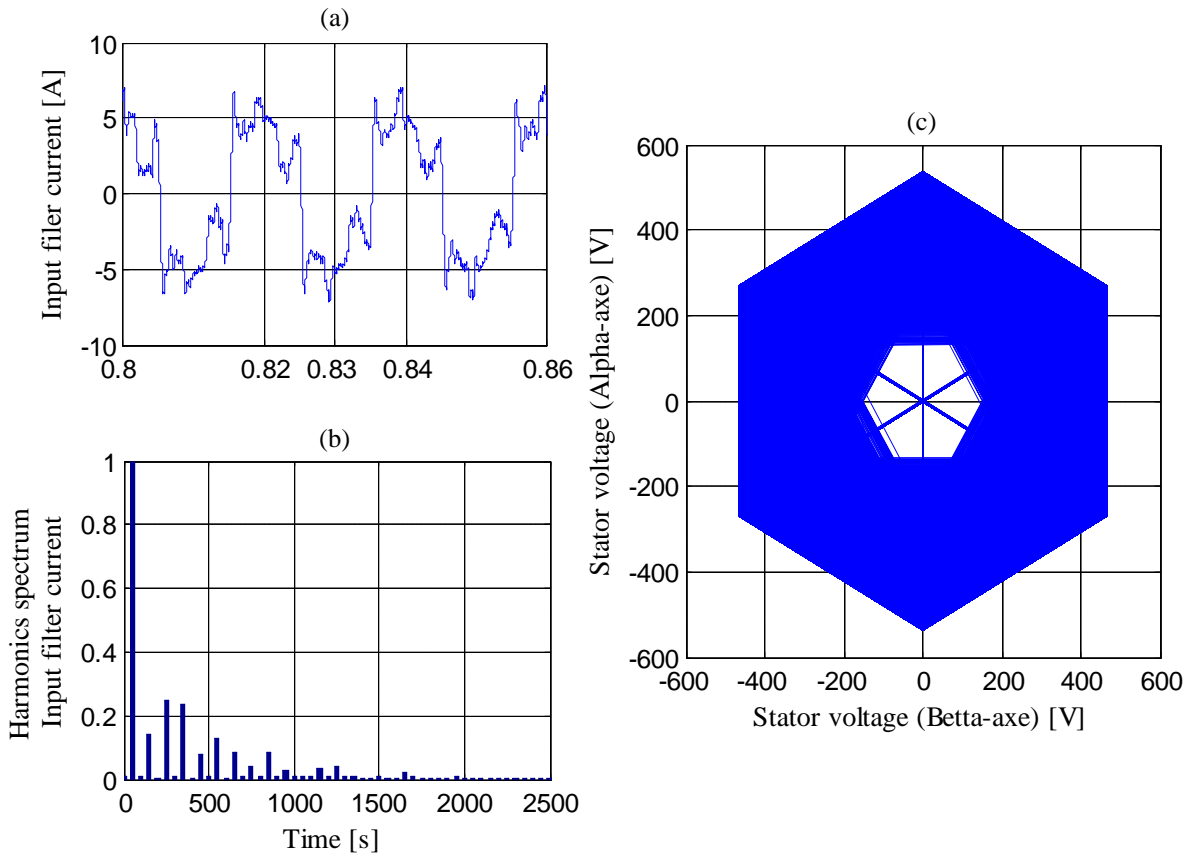

Fig. 7. Results of: (a) input filter current; (b) its harmonics spectrum; (c) space vector of stator voltage ( $v_{s\beta} = f(v_{s\beta})$ ) in fixed reference frame ( $\alpha, \beta$ ).

Figure 7 shows the waveforms of the input filter current and its harmonics spectrum, and space vector of stator voltage ( $v_{s\beta} = f(v_{s\alpha})$ ) in fixed reference frame ( $\alpha, \beta$ ). From this figure, one can see, the variation range of the space vector amplitude of the stator voltage is large (fig.7.c). The waveform of the input filter current is closer to the sinusoidal form (fig.7.a); this is interpreted by the harmonic spectrum (fig.7.b). Therefore, the use of SMC need a better parameter optimization or other configuration for the input filter, as well and if necessary we can use a second filter to the output of the MC, or an active input filter in order to minimize harmonic rate.

## 6. CONCLUSION

In this study, a high performance of the proposed control scheme was presented. Furthermore, the decoupling between speed and rotor flux, stability, robustness, and reliability of the drive system have been ensured under external disturbances (load torque, reference speed and rotor flux variations).

The proposed solution is suitable for any high dynamic performance applications. The use of the DSVM control technique for matrix converter, make possible an operation of induction motor in the four quadrants. The conventional input LC filter is well adapted to filtering of harmonics, due to the simplicity of implementation, and satisfactory performance provided. Therefore, the use of SMC need a better parameter optimization or other configuration for the input filter, as well and if necessary we can use a second filter to the output of the MC, or an active input filter in order to minimize harmonic rate.

A reading of these results, the practical implementation of the proposed drive system is considered as a prospect for the continuation of this work.

## REFERENCES

- Bakhti I. (2007). *Different nonlinear controls of sensorless induction machine with flux and speed observers*. Master thesis, University of Batna, Algeria.
- Bekhouche L. (2009). *Input-output linearizing control by Torque and flux of induction machine*. Master thesis, University of Setif, Algeria.
- Casadei D., Serra G. and Tani A. (2002). Matrix converter modulation Strategies: A new general approach based on space-vector representation of the switch state. *IEEE Trans, Ind. Electronics*, 49(2), 370-381.
- Dendouga, A., Abdessemed, R., and Essounbouli, N. (2013). Robustness evaluation of vector control of induction motor fed by SVM matrix converter. In *IEEE Proc. of 3<sup>rd</sup> Int.Conf. on Systems and Control*, TuBA.6, Algiers, Algeria.
- Hongwu S., Hua L., Xingwei W. and Limin Y. (2009). Damped input filter design of matrix converter. In *Proc. Power electronics and drive systems*, 672-677.
- Huber, L., and Borojevic, D. (1995) Space vector modulation three-phase to three-phase matrix converter with input power factor correction. *IEEE Trans. on industry applications*, 31(6), 1234-1246.
- Lee H.H., and Nguyen H.M. (2006). Direct rotor-flux-oriented control method using matrix converter fed induction motor. *IEEE Proc, IFOST'2005*, 309-313.
- Marino R., Peresada S., and Valigi P. (1993). Adaptive input-output linearizing control of induction motors. *IEEE Trans. on Aut. Cont.*, 38, 208-221.
- Merabet A. (2007). *Nonlinear predictive control of induction motor drive*. Doctorate thesis, University of Quebec.
- Piriyawong V. (2007). *Design and implementation of simple commutation method matrix converter*. Master of science thesis, King mongkut's Institute of technology, North Bangkok, Thailand.
- Rodriguez J., Silva E. and Blaabjerk F. (1985). Modelling, analysis and simulation of matrix converters, *Applications*, IA-21(6), 1337-1342.
- Slotine J-J., and Li W. (1991). *Applied non linear control*", Prentice-Hall Press, New Jersey, USA.
- Sun K., Huang L., and Zhou D. (2005). A nonlinear robust controller for matrix converter fed induction motor drives. *IEEE Trans. on Aut. Cont.* 38, 1365-1370.
- Tarbouchi, M. (1997). *Exact linearization control of induction machine in defluxated mode*. Ph.D thesis, Laval university, Quebec.
- Watanabe, E., Ishii S., Yamamoto E., Hara H., Kang J-K., and Hava A.M. (2000). High performance motor drive using matrix converter. In *IEE Seminar, Advances in Motor Control*, 1-6.
- Wheeler, P.W., Rodrigues, J., and Clare, J.C. (2002). Matrix converters: Technology Review. *IEEE Trans, Ind. Electronics*, 49(2), 276-288.
- Zhang, L., Watthanasarn, C., and Shepherd W. (1998). Analysis and comparison of the control techniques for AC-AC matrix converters. *IEE Proc-Elect., Power Appl*, 145(4), 284-294.
- Yazdanpanah, R., Soltani J., and Markadeh G. R. (2008). Nonlinear torque and stator flux controller for induction motor drive based on adaptive input-output feedback linearization and sliding mode control. *Elsevier, Energy conversion and management*, 49, 541-550.

## APPENDIX

■ Induction motor parameters:			
$R_s$	stator resistance	2.47 $\Omega$	
$R_r$	rotor resistance	1.24 $\Omega$	
$L_s$	stator inductance	0.236 H	
$L_r$	rotor inductance	0.236 H	
$L_m$	magnetizing inductance	0.2269 H	
$J$	total rotor inertia	0.05 kg.m <sup>2</sup>	
$f$	viscous friction coefficient	0.00065 N.m./rd	
$n_p$	pole pairs	2	
■ Input filter parameters:			
$C_f=0.0000252$	F,	$L_f=0.0007$ ;	$R_f=3 \Omega$ .